

FD75 DKD with UCA

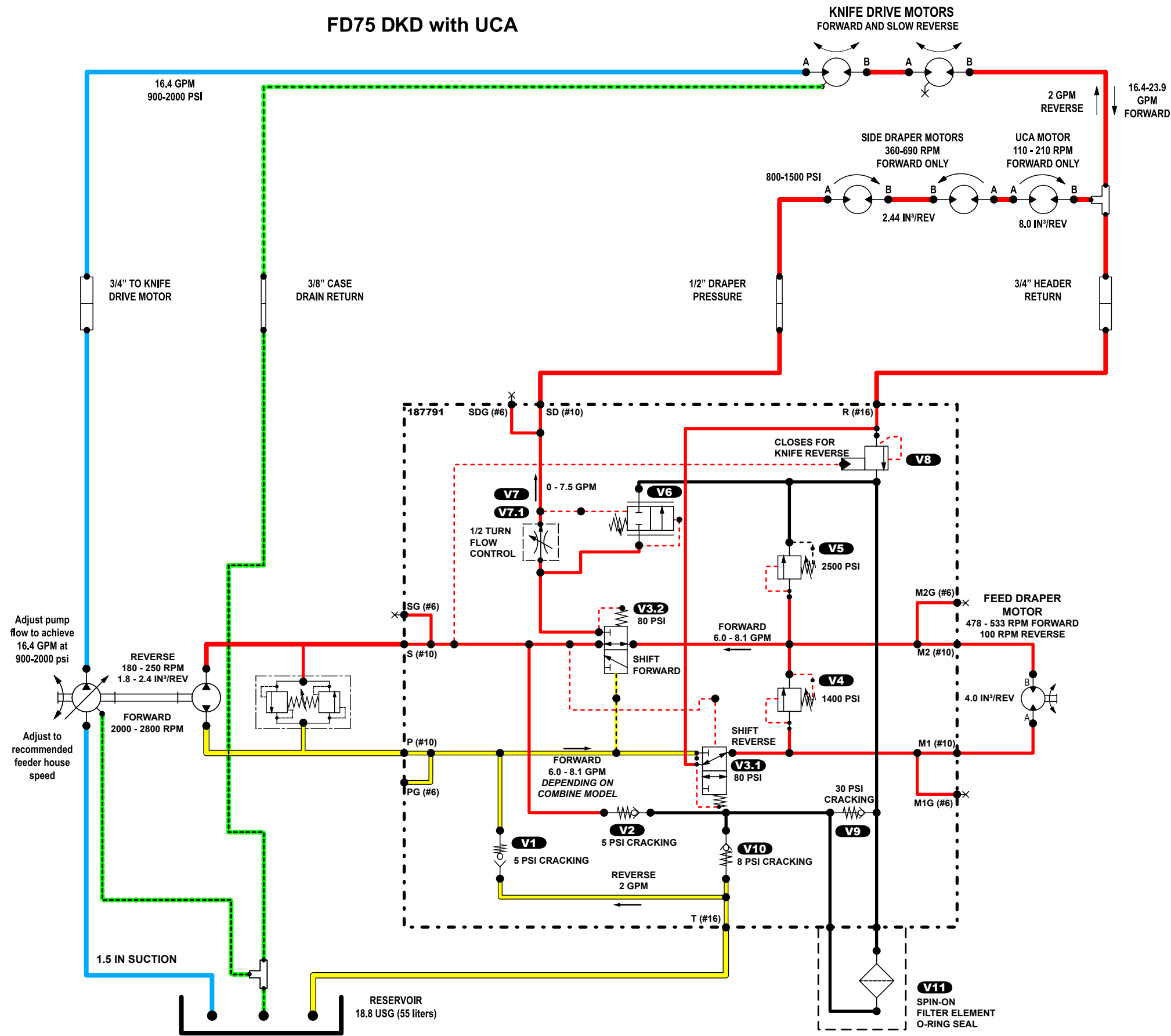

**BOSCH
MANIFOLD**

**REVERSE
KNIFE PRESSURE
AND RETURN
V1 OPEN
V3.1 SHIFTED
V8 CLOSED**

LEGEND

- PRESSURE —
- RETURN —
- SUCTION —
- CASE DRAIN - - -

FD75 DKD with UCA

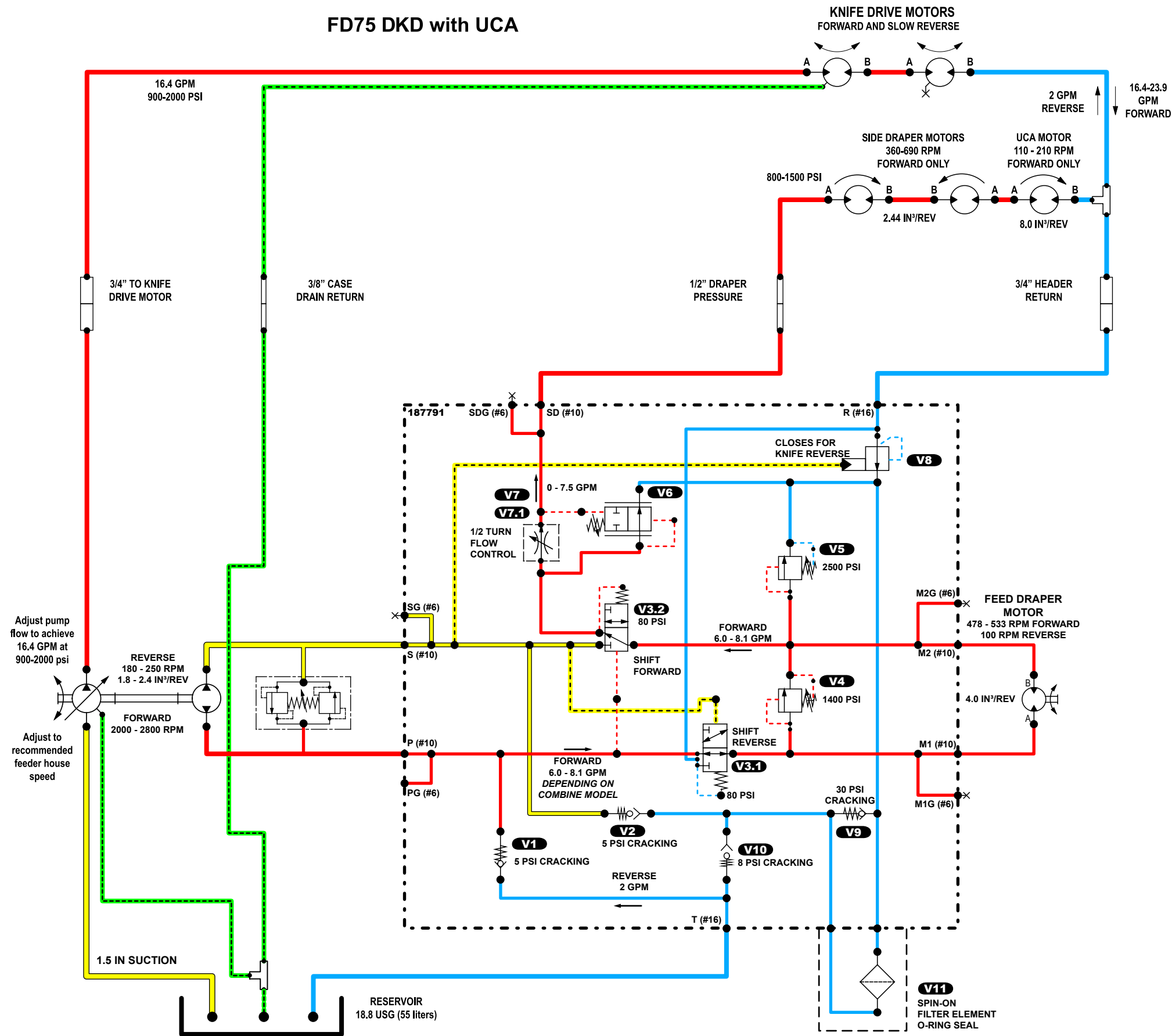

**BOSCH
MANIFOLD
FORWARD
COMPLETE
CIRCUIT
V10 OPEN
V8 OPEN
V3.2 SHIFTED**

LEGEND

PRESSURE	—
RETURN	—
SUCTION	—
CASE DRAIN	- - -