

PART NO
AGA3644



PART OF ASSY

Contents of A3724 fastener kit

| Description | Qty | Drawing No. | TPA Part No. |
|---|-----|-------------|--------------|
| Swell latch assembly - Southco 19-14-10 | 2 | | F425 |
| Nut M10 - Galvanized | 8 | | AGF426 |
| Flat washer M10 - Galvanized | 8 | | AGF440 |
| Thick washer M12 - 32 O/D x 2 thk - Galvanized | 2 | | F441 |
| DIN 933 Hex head bolt, washer & nut ass'y M12 x 30 - Galvanized | 2 | | F429 |
| DIN 603 Carriage bolt M10 x 25 - Galvanized | 8 | | AGF430 |
| DIN 7991 SH CSK Screw M6 x 12 - Stainless St. | 3 | | F431 |
| Stand-off bolt | 3 | 002860 | F422 |
| Screw M5 x 12 SH C/SK - SS | 3 | | AGF541 |

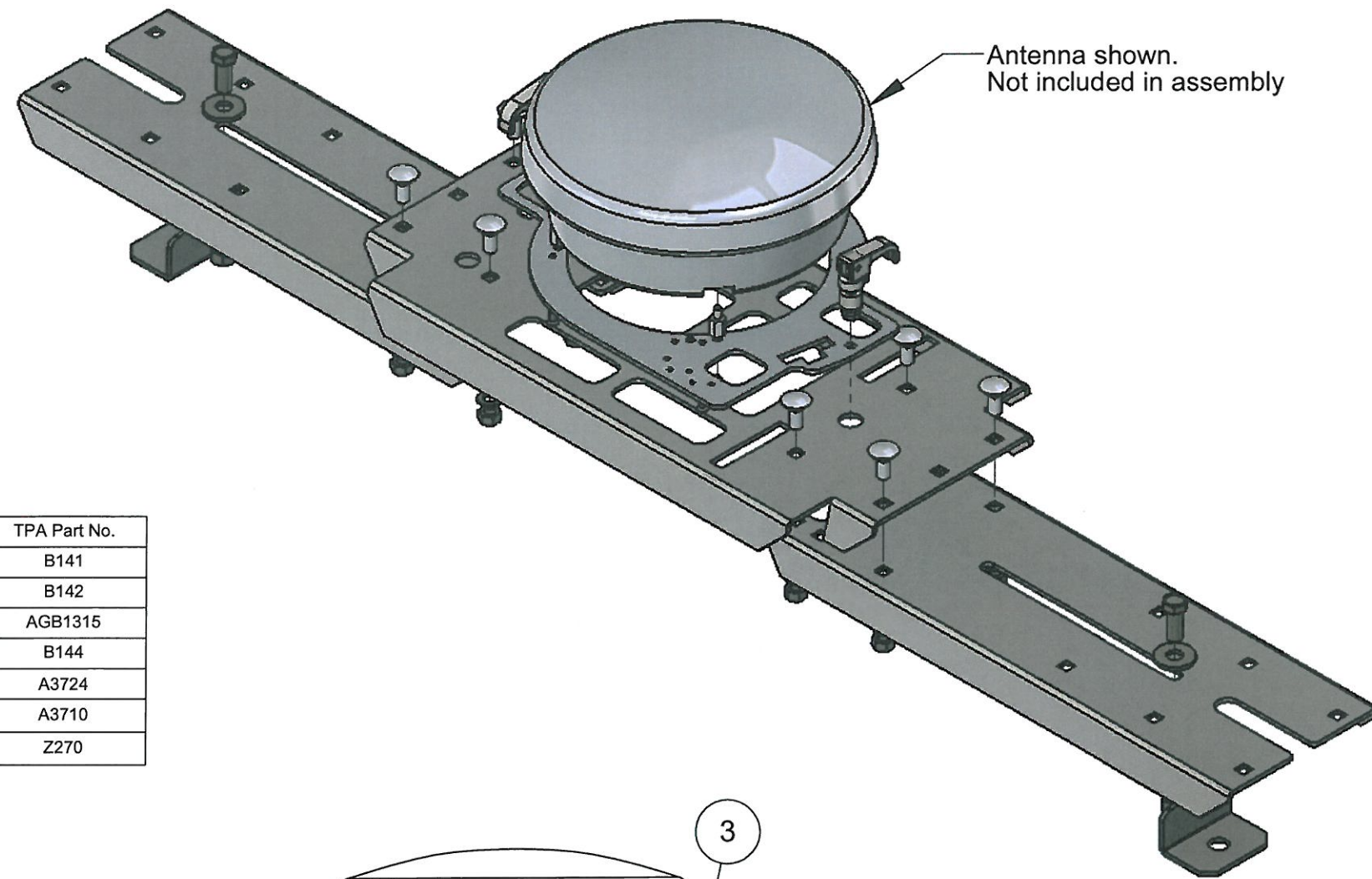

| Item No. | Qty | Description | Drawing No. | TPA Part No. |
|----------|-----|--|-------------|--------------|
| 1 | 1 | Bracket plate - centre | 002838 | B141 |
| 2 | 2 | Bracket plate - outer | 002839 | B142 |
| 3 | 1 | AGI-3 / AGI4 Adaptor bracket | 004392 | AGB1315 |
| 4 | 2 | Mounting foot | 002841 | B144 |
| 5 | 1 | Fastener kit - Generic roof brkt (see table above) | - | A3724 |
| 7 | 1 | System 150 AGI-3 Generic mount installation instructions | - | A3710 |
| 9 | 1 | Carton - System 150 AGI-3 | - | Z270 |

Torque settings (based on min. 8,8 tensile grade for bolts)

| Item No. | Thread spec. | Torque (Nm) | No. off |
|----------|--------------|-------------|---------|
| T1 | M6 x 1.0 | 8 | 3 |
| T2 | M5 x 0.7 | 5 | 3 |
| T3 | M10 x 1.5 | 30 | 8 |
| T4 | M12 x 1.75 | 50 | 2 |

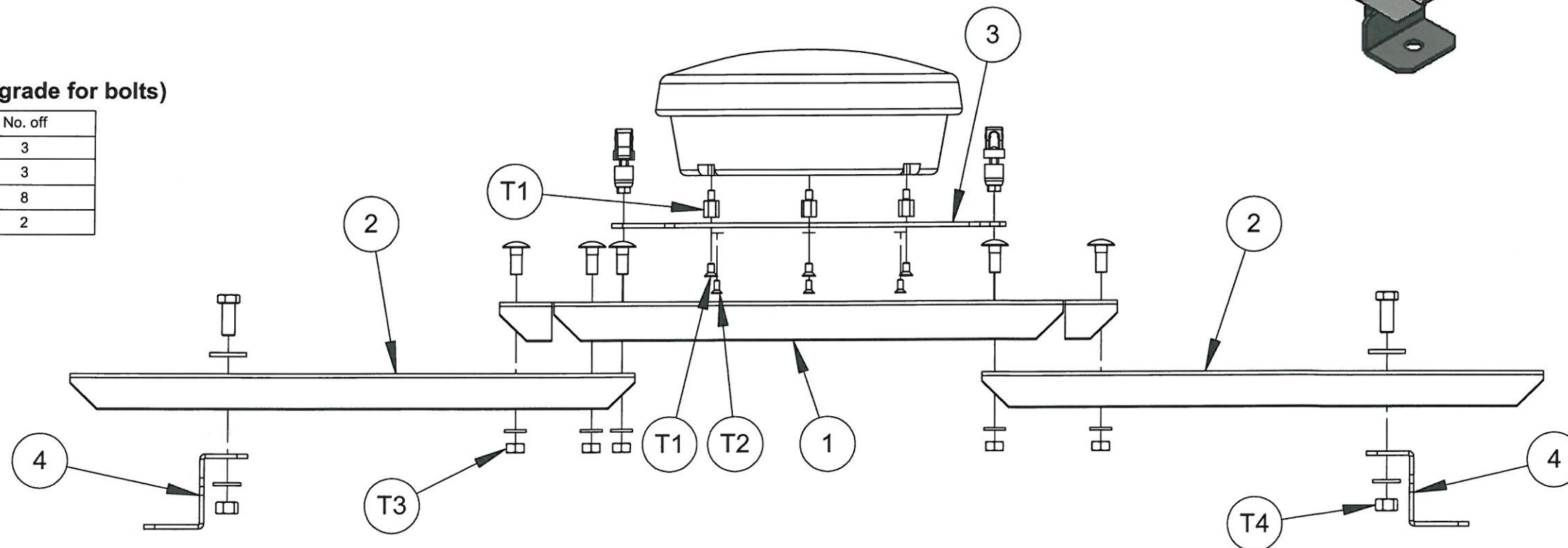

| REV | DATE | ECO | DESCRIPTION | CHK | DRWN | APPD | MATERIAL | MACHINING TOLERANCES | DRAWN BY | DATE | PART OF ASSY | PART NUMBER | PROJECT | SHEET SIZE | | | | |
|-------|----------|-------|--|-----|------|------|----------|--|--|----------|---|----------------------------|-----------------------|--------------|----------------------------|--|--------------------------------|--|
| 1.0 | 13/11/08 | | Production release | | RC | MW | | X ± 0.1 X.X ± 0.2 X.XX ± AS STATED ANGULAR ± 0.25° | RC | 13/11/08 | | AGA3644 | 2128 | A3 | | | | |
| 1.1 | 25/11/08 | 0250 | M12 nut & washer incorporated into F429 Bolt ass'y | | RC | MW | | | OM | 17/11/08 | MACHINE FINISH 3.2 | | | SCALE 1:5 | | | | |
| 1.1.1 | 18/07/10 | CO317 | P/n was A3644, AGFs were Fs | OM | RC | KM | | | MW | 17/11/08 | DO NOT SCALE UNLESS OTHERWISE STATED ALL DIMENSIONS ARE IN MILLIMETERS | | | SHEET 1 OF 1 | | | | |
| 1.2 | 21/03/11 | 634 | AGB1248 was B145, AGF541 added. | OM | RC | KM | FINISH | | | | | AGI-3/4 Generic mount brkt | | REVISION 1.3 | | | | |
| 1.3 | 28/01/13 | 1062 | AGB1315 replaces AGB1248 | OM | RC | KM | | HARNES TOLERANCES 0-300 +5 / -3 300-1000 +10 / -5 1000-3000 +20 / -10 3000-5000 +40 / -20 STRIP LENGTHS +0.5 / -0 | | | | | | | | | | |
| | | | | | | | | | TOPCON Precision Agriculture 14 PARK WAY MAWSON LAKES SOUTH AUSTRALIA 5095 | | PHONE: (+618)82033300 FAX: 1300307205 EMAIL: info@kee.com.au WEB: www.kee.com.au | | DRAWING NO. 002868 | | DRAWING STANDARD AS1100 | | SECURITY CLASS CONFIDENTIAL | |

COPYRIGHT: THIS DRAWING IS THE PROPERTY OF TOPCON PRECISION AGRICULTURE. IT MAY NOT BE REPRODUCED IN WHOLE OR IN PART WITHOUT THEIR WRITTEN PERMISSION

UNLESS OTHERWISE STATED, ALL PRINTED COPIES OF THIS DOCUMENT ARE UNCONTROLLED. REFER TO DRAWING REGISTER FOR LATEST RELEASE